

CBB-XX	RU	"A"	"B"	"C"	"D"
CBB-20	20	35.00	1.75	10	17.50
CBB-24	24	42.00	1.75	11	21.00
CBB-25	25	44.25	4.38	9	22.12
CBB-30	30	52.50	1.75	15	26.25
CBB-35	35	61.25	4.38	16	30.63
CBB-40	40	70.00	1.75	20	35.00
CBB-42	42	73.50	1.75	21	36.75
CBB-44	44	77.00	1.75	22	38.50
CBB-45	45	78.75	4.38	21	39.38
CBB-47	47	82.25	4.38	22	41.13
CBB-48	48	84.00	1.75	24	42.00
CBB-50	50	87.50	1.75	25	43.75

DWG. NO.
S-CBB-xx

SHIP WITH/INSTALLED WITH
(3) 1/4-20 x 3/4" SERRATED WASHER HEAD BOLT
(3) 1/4-20 UNISTRUT NUTS

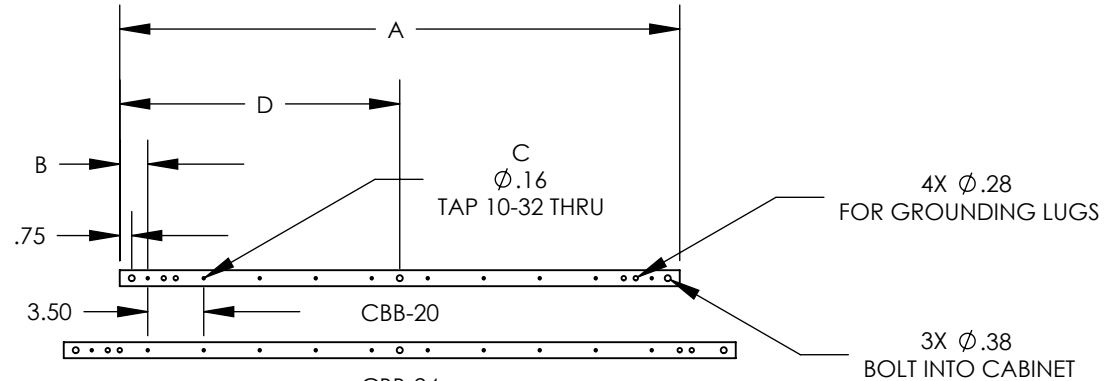

NOTE:

CBB-25 HAS ADDITIONAL MOUNTING LOCATIONS TO ACT AS A "HALF HEIGHT" BUSS BAR FOR 50U, 48U, 47U, 45U, 42U AND 40U.



PROPRIETARY AND CONFIDENTIAL

This drawing embodies a confidential proprietary design owned by Electrorack Products Company and all design, manufacturing, reproduction, use and sales rights regarding this drawing are reserved to Electrorack Products Company. The recipient of this drawing assumes custody thereof and agrees that the information contained herein shall not be used, duplicated or disclosed to reproduce articles or subject matter therein without written permission of Electrorack Products Company.

TITLE:

COPPER BUSS BAR

FINISH
NONE

MATERIAL
1/4" x 1.00"
COPPER BAR

REV DATE

08/24/07

SHEET 1 OF 1