

INSTALLATION HARDWARE:  
 (8) 10-32 x 5/8" TRUSS HEAD SCREWS

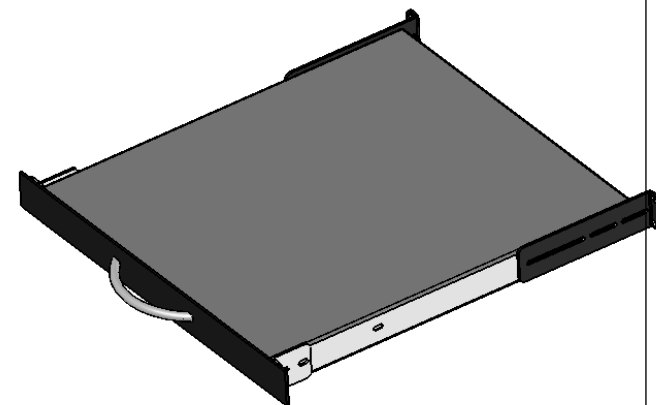

**PROPRIETARY AND CONFIDENTIAL**

This drawing embodies a confidential proprietary design owned by Electrorack Products Company and all design, manufacturing, reproduction, use and sales rights regarding this drawing are reserved to Electrorack Products Company. The recipient of this drawing assumes custody thereof and agrees that the information contained herein shall not be used, duplicated or disclosed to reproduce articles or subject matter therein without written permission of Electrorack Products Company.

TITLE:  
**1U SLIDE WRITING SURFACE**

FINISH  
 MATERIAL  
 SEE BOM

REV DATE  
 03/27/08  
 SHEET 1 OF 1