

Electrorack's Whisper™ Wall Cabinets are the perfect solution for rack-
ing remote patch panels, hubs & switches.

The optional smaller quieter fan makes it an ideal choice when mount-
ed in an open office environment. The 50 cfm fan is **50% quieter**
than other leading cabinets and provides enough airflow to com-
pletely exchange the air in the cabinet 7 times per minute*.

Our heavy-duty construction & die cast hinges minimize sagging
under heavy loads and feature non-removable pins for added
security.

Locking wing turn latch allows cabinet to be opened and closed
without having to lock the cabinet. This allows "key-free" and
easy access when used in a secure data closet.

The 24" width & specialized cable pass openings in the equip-
ment mounting angles provide front to rear cable access along
the sides of the cabinet - saving valuable useable rack space.

■ ■ ■ Key Features

- heavy duty all 14 gauge (0.075") steel construction (front door 16 gauge)
- vented sides allow cooling of active equipment
- optional "low-noise" fan can be added for additional cooling
- ships with one pair of 12-24 tapped mounting angles
- mounting angles are fully adjustable - front to rear
- your choice of solid or smoked acrylic front door
- 3" removable cable access holes top & bottom
- durable black powder coated finish
- 12 standard sizes available



Design Features

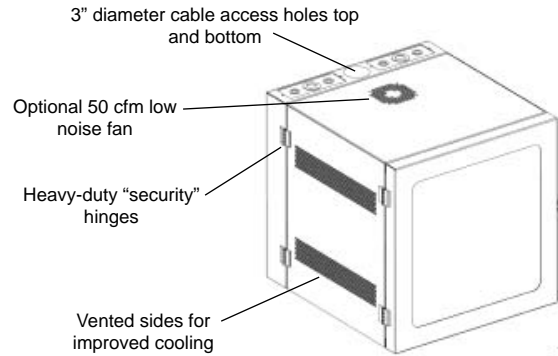
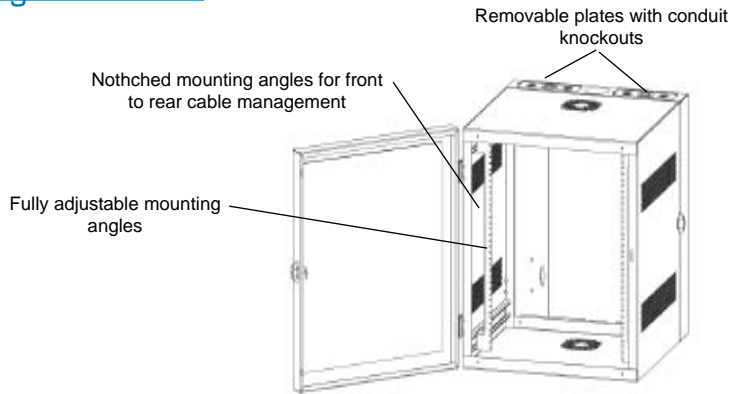

Ordering Information

PART NUMBER	RACK UNITS	DOOR STYLE	OVERALL HEIGHT	USABLE DEPTH	OVERALL DEPTH	OVERALL WIDTH
STANDARD DEPTH						
2 Foot Tall						
WC2-14SV-2	12U (21.00")	solid	23.50"	14.00"	20.20"	24.00"
WC2-14PV-2	12U (21.00")	plexiglass	23.50"	14.00"	20.20"	24.00"
3 Foot Tall						
WC3-14SV-2	19U (33.25")	solid	35.75"	14.00"	20.20"	24.00"
WC3-14PV-2	19U (33.25")	plexiglass	35.75"	14.00"	20.20"	24.00"
4 Foot Tall						
WC4-14SV-2	26U (45.50")	solid	48.00"	14.00"	20.20"	24.00"
WC4-14PV-2	26U (45.50")	plexiglass	48.00"	14.00"	20.20"	24.00"
EXTRA DEPTH						
2 Foot Tall						
WC2-20SV-2	12U (21.00")	solid	23.50"	20.00"	26.20"	24.00"
WC2-20PV-2	12U (21.00")	plexiglass	23.50"	20.00"	26.20"	24.00"
3 Foot Tall						
WC3-20SV-2	19U (33.25")	solid	35.75"	20.00"	26.20"	24.00"
WC3-20PV-2	19U (33.25")	plexiglass	35.75"	20.00"	26.20"	24.00"
4 Foot Tall						
WC4-20SV-2	26U (45.50")	solid	48.00"	20.00"	26.20"	24.00"
WC4-20PV-2	26U (45.50")	plexiglass	48.00"	20.00"	26.20"	24.00"
ACCESSORIES						
FAN-4WC	50 cfm fan with finger guard & 2' powercord					
WC-12LRT-2	12U mounting angle pair - tapped 12-24					
WC-19LRT-2	19U mounting angle pair - tapped 12-24					
WC-26LRT-2	26U mounting angle pair - tapped 12-24					

